

# PRA

## PERIPHERAL ELECTRIC PUMPS

in cast iron



### PERFORMANCE CURVES (according to ISO 9906 Attachment 3B)

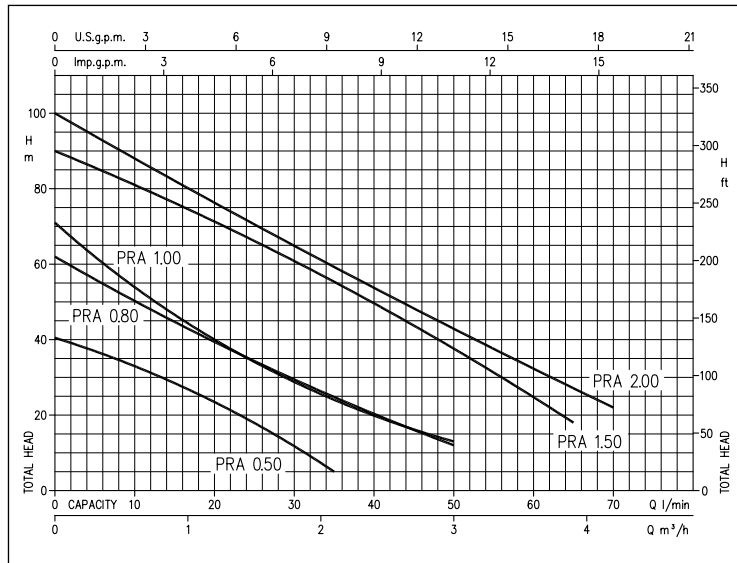

### IDENTIFICATION CODE

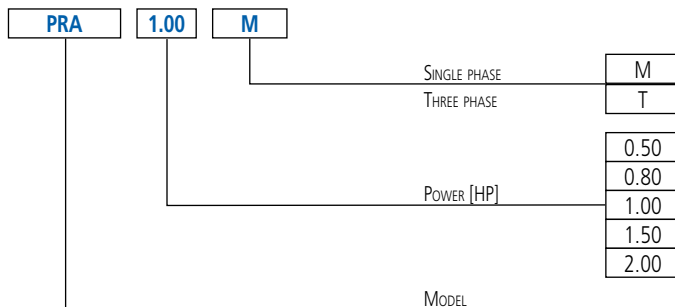

Cast iron peripheral electric pumps

### APPLICATIONS

- Suitable for domestic uses
- Boilers power supply and booster units
- Autoclave groups

### TECHNICAL DETAILS

- They're silent
- Practical
- Easy to transport
- Available also in the nickel-plated version (PRN 0.50 model)

### PUMP TECHNICAL DATA

- Maximum working pressure:
  - 6 bar for PRA 0.50
  - 7.5 bar for PRA 0.80
  - 12 bar for the rest of the range
- Maximum temperature of the liquid: 80° C
- G1 discharge connection
- G1 suction connection

### MOTOR TECHNICAL DATA

- IE3 high energy-efficiency motors starting from 0.75kW
- Asynchronous motor, 2 poles
- Class of insulation F
- IP44 Protection degree
- 230V ± 10% 50Hz single phase voltage, 230/400V ±10% 50Hz three phase voltage
- Permanent capacitor inserted and thermo-amperometric protection with automatic rearm incorporated for the single phase motor
- Protection under user's responsibility for the three phase version

### MATERIALS

- Cast iron pump body and support
- Shaft in AVZ steel for the PRA 0.50 model, in AISI 303 (portion in contact with the liquid) for the rest of the range
- Brass impeller
- Mechanical seal in Carbon/Ceramic/NBR

### ACCESSORIES (On request)

- Electric panels
- Vessels
- Floats
- Pressure switches
- Presscomfort - Pressure regulator
- E-power - Variable speed control system
- E-drive - Frequency converter

# PRA

## PERIPHERAL ELECTRIC PUMPS

in cast iron

### PERFORMANCE CHART

Model		P <sub>2</sub>		l/min m <sup>3</sup> /h	Q = Flow Rate							
Single phase 230V	Three phase 230/400V	[HP]	[kW]		5	10	15	20	35	50	65	70
					0.3	0.6	0.9	1.2	2.1	3	3.9	4.2
				H=Head [m]								
PRA 0.50 M	PRA 0.50 T	0.5	0.37	37.0	33.3	28.7	23.7	5.0	-	-	-	-
PRA 0.80 M	PRA 0.80 T	0.8	0.6	56.0	50.7	45.1	39.8	25.0	12.0	-	-	-
PRA 1.00 M	PRA 1.00 T	1	0.75	62.0	54.4	47.0	40.4	24.3	13.0	-	-	-
PRA 1.50 M	PRA 1.50 T	1.5	1.1	-	81.0	76.9	71.9	55.8	37.9	18.0	-	-
PRA 2.00 M	PRA 2.00 T	2	1.5	-	88.0	82.9	77.0	59.8	43.3	27.4	22.0	-

### DIMENSIONS

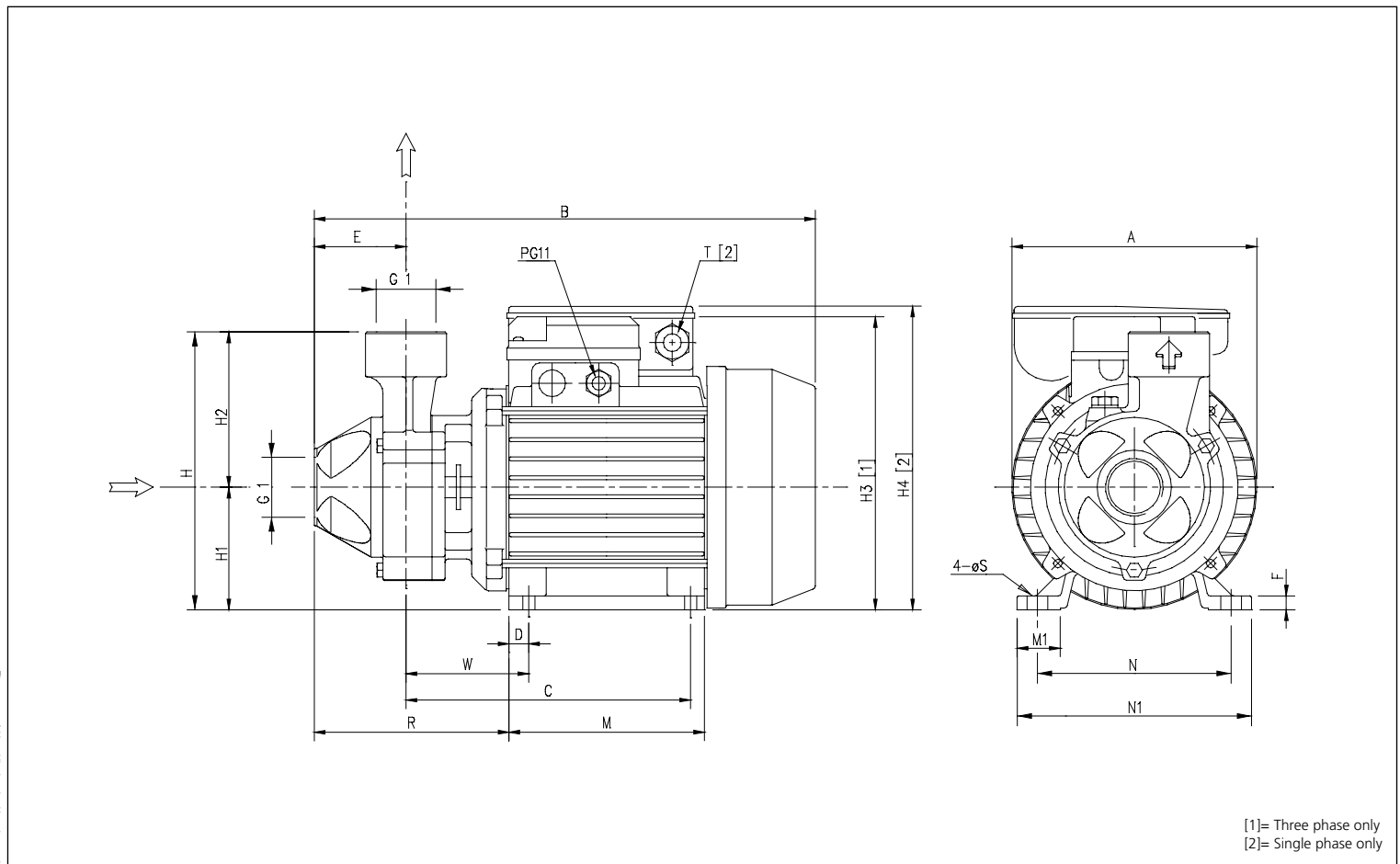

[1]= Three phase only  
[2]= Single phase only

### DIMENSIONS TABLE

Model	Dimensions [mm]																			Weight [kg]	
	A	B	C	D	E	F	H	H1	H2	H3	H4	M	M1	N	N1	R	T [2]	V [1]	W		
PRA 0.50M	130	264	149	10	50	7	143	63	80	-	160	100	23	100	120	119	PG11	-	69	7	5,6
PRA 0.50T	130	264	149	10	50	7	143	63	80	150	-	100	23	100	120	119	-	PG11	69	7	5,6
PRA 0.80M	130	291	159	11	54	9	161	71	90	-	178	112	25	112	135	122	PG11	-	69	7	9,2
PRA 0.80T	150	291	159	11	54	9	161	71	90	168	-	112	25	112	135	122	-	PG11	69	7	9,2
PRA 1.00M	150	291	159	11	54	9	161	71	90	-	178	112	25	112	135	122	PG11	-	69	7	9,7
PRA 1.00T	150	291	159	11	54	9	161	71	90	168	-	112	25	112	135	122	-	M16x1.5	69	7	10,5
PRA 1.50M	162	331	188	12	57	12	175	80	95	-	212	124	28	125	152	144	PG13.5	-	88	9	14,5
PRA 1.50T	162	356	188	12	57	12	175	80	95	187	-	124	28	125	152	144	-	M20x1.5	88	9	16,4
PRA 2.00M	162	331	188	12	57	12	175	80	95	-	212	124	28	125	152	144	PG13.5	-	88	9	15,8
PRA 2.00T	162	357	188	12	57	12	175	80	95	187	-	124	28	125	152	144	-	M20x1.5	88	9	17,3

[1]= Three phase only  
[2]= Single phase only

## PERIPHERAL ELECTRIC PUMPS

in cast iron

### SECTIONAL VIEW

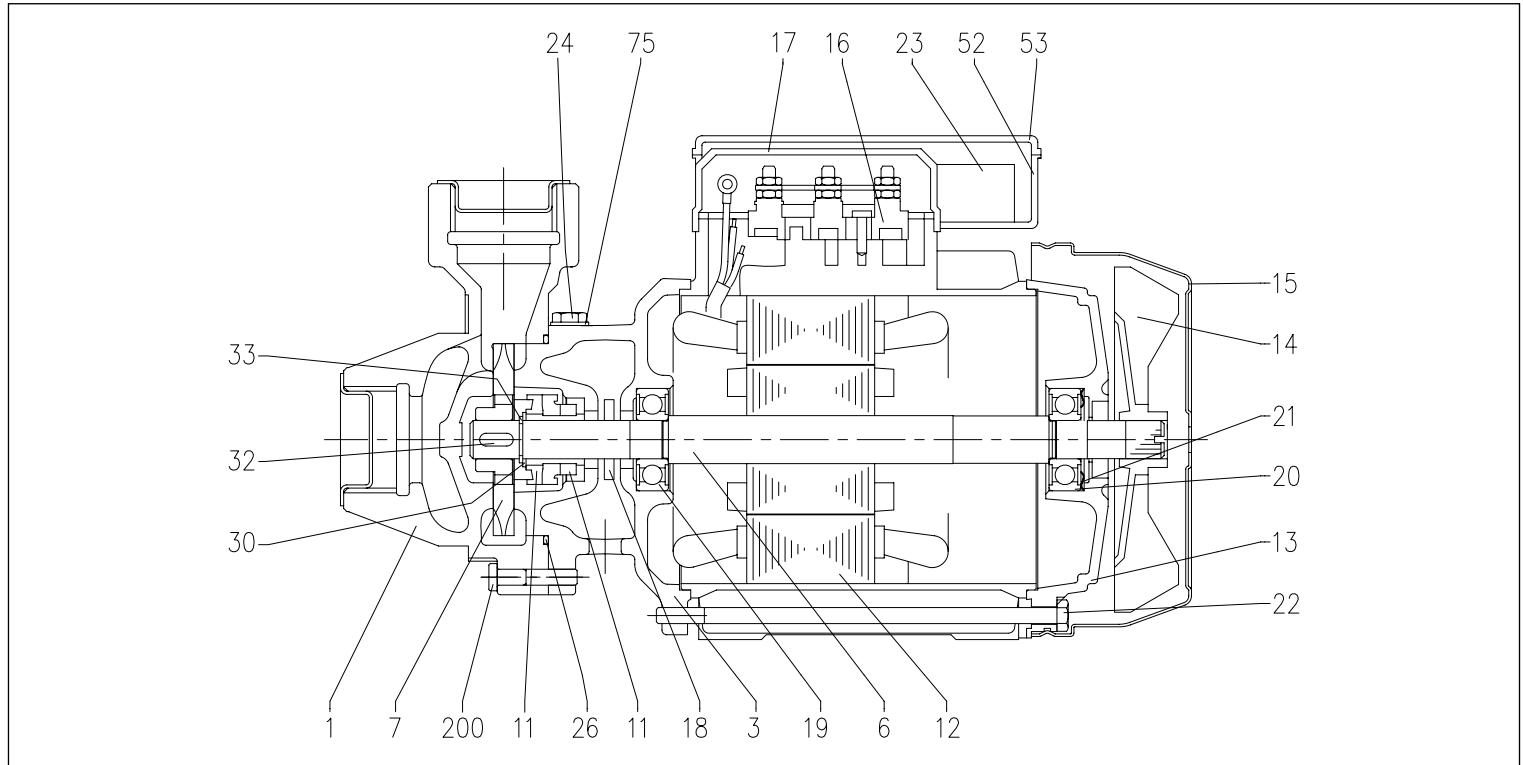

### MATERIALS TABLE

Ref.	Name	Material	Ref.	Name	Material
1	Pump body	Cast iron	20	Bearing (motor side)	-
3	Motor support	Cast iron	21	Adjustment ring	Steel C70
6	Shaft with rotor	[3]	22	Tie-rod	Galvanised Fe 42
7	Impeller	Brass	23	Capacitor [2]	-
11	Mechanical seal	Carbon/Ceramic/NBR	24	Filler cap	Brass
12	Motor casing with stator	-	26	O-Ring	NBR
13	Motor cover	Aluminium	30	Washer	AISI 304
14	Fan	PP	32	Key	AISI 316
15	Fan cover	Galvanised Fe P04	33	Ring	AISI 304
16	Terminal Box	-	52	Capacitor-holder box [2]	ABS
17	Terminal Box cover [1]	Aluminium	53	Capacitor-holder box cover [2]	ABS
18	Spray protector ring	NBR	75	Washer	Aluminium
19	Bearing (pump side)	-	200	Screw	Zn. stainless steel Cl. 8.8

[1]= For three phase only [2]= For single phase only

[3]= Material: AVZ for PRA 0.50, AISI 303 (part in contact with the liquid) for the rest of the range

### MECHANICAL SEAL for PRA 0.50 - 0.80 - 1.00

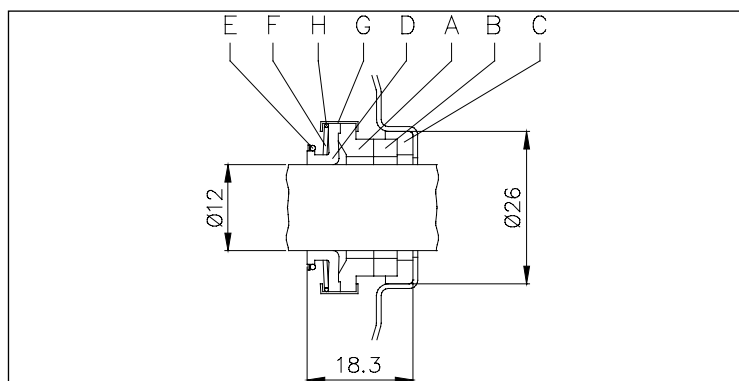

### MATERIALS TABLE for PRA 0.50 - 0.80 - 1.00

Ref.	Name	Material
A	Rotating part	Carbon
B	Fixed part	Ceramic
C	Gasket	NBR
D	Diaphragm	NBR
E	Ring	AISI 304
F	Spring	AISI 304
G	Structure/frame	AISI 304
H	Retainer ring	AISI 304

## PERIPHERAL ELECTRIC PUMPS

in cast iron

**MECHANICAL SEAL** for PRA 1.50 - 2.00

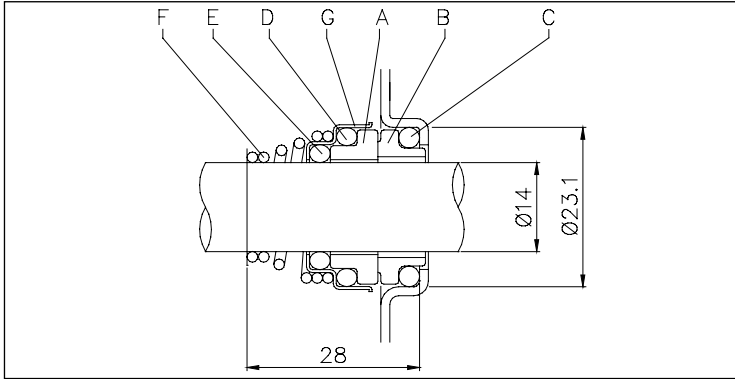

**MATERIALS TABLE** for PRA 1.50 - 2.00

Ref.	Name	Material
A	Rotating part	Ceramic
B	Fixed part	Carbon
C	O-Ring	NBR
D	O-Ring	NBR
E	O-Ring	NBR
F	Spring	AISI 316
G	Structure/frame	AISI 304

**ELECTRIC DATA TABLE**

Model Single phase 230V	Model Three phase 230/400V	P <sub>2</sub>		Efficiency		Capacitor		Efficiency (%)			P <sub>1</sub>		Absorbed Current [A]		
		[HP]	[kW]	Single phase	Three phase	Single phase μF	V <sub>c</sub>	50%	75%	100%	Single phase [kW]	Three phase [kW]	Single phase 230V	Three phase 230V	Three phase 400V
		η %													
PRA 0.50 M	PRA 0.50 T	0,5	0,37	-	-	10	450	-	-	-	0,57	0,55	2,6	1,7	1,0
PRA 0.80 M	PRA 0.80 T	0,8	0,6	-	-	16	450	-	-	-	1,10	1,10	4,9	3,6	2,1
PRA 1.00 M	PRA 1.00 T	1	0,75	-	IE3	20	450	80,9	82,3	82,1	1,25	0,91	5,6	3,0	1,7
PRA 1.50 M	PRA 1.50 T	1,5	1,1	-	IE3	40	450	83,5	84,3	84,6	2,27	1,77	10,0	5,8	3,3
PRA 2.00 M	PRA 2.00 T	2	1,5	-	IE3	40	450	82,7	86,1	87,0	2,45	1,72	10,9	6,6	3,8

**NOISE DATA TABLE**

Model Single phase 230V	Model Three phase 230/400V	P <sub>2</sub>		L <sub>PA</sub> - dB(A)*
		[HP]	[kW]	
PRA 0.50 M	PRA 0.50 T	0.5	0.37	<70
PRA 0.80 M	PRA 0.80 T	0.8	0.6	
PRA 1.00 M	PRA 1.00 T	1	0.75	
PRA 1.50 M	PRA 1.50 T	1.5	1.1	73
PRA 2.00 M	PRA 2.00 T	2	1.5	

\* Average noise level measured at 1 m from the motor pump.  
Tolerance ± 2.5 dB.